

### Operating Instructions, Parts List & Warranty

#### IMPORTANT! Read carefully before operating this tool.

Failure to operate any power tool properly can result in personal injury and/or property damage!



##### 7.2.2.3 GENERAL SAFETY RULES

- Multiple hazards. Read and understand the safety instructions before installing, operating, repairing, maintaining, changing accessories on, or working near the power tool. Failure to do so can result in serious bodily injury.
- Only qualified and trained operators should install, adjust or use the power tool.
- Do not modify this power tool. Modifications may reduce the effectiveness of safety measures and increase the risks to the operator.
- Do not discard the safety instructions – give them to the operator.
- Do not use a tool if the tool has been damaged.
- Warnings shall be given against the risk of explosion or fire due to the material being processed.
- Warnings shall be given against the risk of cutting.



##### 7.2.2.4 PROJECTILE HAZARDS

- Failure of the work piece, of accessories, or even of the tool itself may generate high velocity projectiles.
- Always wear impact-resistant eye protection during operation of the tool. The grade of protection required should be assessed for each use.



##### 7.2.2.5 ENTANGLEMENT HAZARDS

- Entanglement hazard – choking, scalping and/or lacerations can occur if neck ware, hair or gloves are not kept away from tool and accessories.

##### 7.2.2.6 OPERATING HAZARDS

- Use of the tool may expose the operator's hands to hazards including crushing, impacts, cuts and abrasions and heat. Wear suitable gloves to protect hands.
- Operators and maintenance personnel must be physically able to handle the bulk, weight and power of the tool.
- Hold the tool correctly: be ready to counteract normal or sudden movements – have both hands available.
- Maintain a balanced body position and secure footing.
- Keep hands away from rotating or reciprocation accessories, spindles or other moving parts.
- Release the start and stop device in the case of an interruption of the energy supply
- Use only lubricants recommended by the manufacturer.



##### 7.2.2.7 REPETITIVE MOTIONS HAZARDS

- When using a power tool, you may experience discomfort in your hands, arms, shoulders, neck, or other parts of your body.
- While using a power tool, position your body in a comfortable posture. Maintain secure footing and avoid awkward or off-balanced postures. Changing your posture during extended tasks may help avoid discomfort and fatigue.
- If you experience symptoms such as persistent or recurring discomfort, pain, throbbing, aching, tingling, numbness, burning sensation, or stiffness, do not ignore these warning signs. Promptly tell your employer and consult a qualified health professional.

##### 7.2.2.8 ACCESSORY HAZARDS

- Only use sizes and types of accessories and consumables that are recommended by the power tool manufacturer.



##### 7.2.2.9 WORKPLACE HAZARDS

- Slips, trips and falls are major causes of workplace injury. Be aware of slippery surfaces caused by use of the tool and also of trip hazards caused by the air line or hydraulic hose.
- Proceed with care in unfamiliar surroundings. Hidden hazards may exist, such as electricity or other utility lines.
- This power tool is not intended for use in potentially explosive atmospheres and is not insulated from coming into contact with electric power.
- Make sure there are no electrical cables, gas pipes etc. that could cause a hazard if damaged by use of the tool.



##### 7.2.2.10 DUST AND FUME HAZARDS

- Dust from some work processes can cause cancer, birth defects or other respiratory diseases. Risk assessment of these hazards and implementation of appropriate controls is essential.

- If the pneumatic tool is used in a dust filled environment exhaust air can cause a dust hazard.
- Dusts and fumes generated when using power tools can cause ill health (for example: cancer, birth defects, asthma and/or dermatitis); risk assessment of these hazards and implementation of appropriate controls of is essential.
- Risk assessment should include dust created by the use of the tool and the potential for disturbing existing dust.
- Operate and maintain the power tool as recommended in these instructions, to minimize dust or fume emissions
- Direct the exhaust so as to minimized disturbance of dust in a dust filled environment
- Where dusts or fumes are created, the priority shall be to control them at the point of emission.
- All integral features or accessories for the collection, extraction or suppression of airborne dust or fumes should be correctly used and maintained in accordance with the manufacturer's instructions.
- Select, maintain and replace the consumable/inserted tool as recommended in these instructions, to prevent an unnecessary increase in dust or fumes.
- Use respiratory protection as instructed by your employer or as required by occupational health and safety regulations;



##### 7.2.2.11 NOISE HAZARDS

- Unprotected exposure to high noise levels can cause permanent, disabling, hearing loss and other problems such as tinnitus (ringing, buzzing, whistling or humming in the ears).
- Risk assessment of these hazards and implementation of appropriate controls of is essential.
- Appropriate controls to reduce the risk may include actions such as damping materials to prevent work pieces from 'ringing'
- Use hearing protection as instructed by your employer or as required by occupational health and safety regulations;
- Operate and maintain the power tool as recommended in these instructions, to prevent an unnecessary increase in noise levels;
- Select, maintain and replace the consumable/inserted tool as recommended in these instructions, to prevent an unnecessary increase in noise.



##### 7.2.2.12 VIBRATION HAZARDS

- Exposure to vibration can cause disabling damage to the nerves and blood supply of the hands and arms;
- Wear warm clothing when working in cold conditions and keep your hands warm and dry.
- If you experience numbness, tingling, pain or whitening of the skin in your fingers or hands, stop using the power tool, and tell your employer. You should also seek medical advice from a qualified occupational health professional.
- Operate and maintain the power tool as recommended in these instructions, to prevent an unnecessary increase in vibration;
- Select, maintain and replace the consumable/inserted tool as recommended in these instructions, to prevent an unnecessary increase in vibration levels;
- Support the weight of the tool in a stand, tensioner or balancer, because the operator can then use a lighter grip to support the tool.
- Hold the tool with a light but safe grip taking account of the required hand reaction forces, because the risk from vibration is generally greater when the grip force is higher.

##### 7.2.3 ADDITIONAL SAFETY INSTRUCTIONS FOR PNEUMATIC POWER TOOLS - AIR SUPPLY & CONNECTION HAZARDS

- Air under pressure can cause severe injury.
- Never direct air at yourself or anyone else.
- Whipping hoses can cause severe injury. Always check for damaged or loose hoses and fittings.
- Whenever universal twist couplings (claw couplings) are used, lock pins must be installed.
- Do not exceed the maximum air pressure stated on the tool.
- Use whip check safety cables to safeguard against possible hose to tool and hose to hose connection failure.
- Never carry an air tool by the hose.

# Important Warnings - Tire Buffers

1. Only use mounted grinding stones or mounted carbide burrs that meet ANSI standards, ISO standards or both.
2. Never adjust the tire buffer, adjust the collets or change the mounted stones or mounted burrs unless the air supply and air hose is disconnected from the tire buffer.
3. Only personnel trained in the correct methods to adjust collets and change mounted stones and mounted burrs should conduct these operations.
4. Always ensure that you are aware of the direction of the sparks being created by the grinding operation and ensure that the sparks are not directed toward the operator or other persons in the area.
5. Never use tire buffer close to any explosive or flammable materials or air conditioners.
6. Only use mounted stones or carbide burrs that have the correct spindle diameter that matches the original collet size provided by the die grinder manufacturer.
7. Particular care must be taken not to use metric size mounted stones and mounted burrs with tire buffers that have imperial size collets, or use imperial mounted stones and mounted burrs with tire buffers that have metric collets.



**WARNING:** This product contains lead, a chemical known to the State of California to cause cancer and birth defects or other reproductive harm. **Wash hands after handling**



**WARNING:** This product contains chemicals known to the State of California to cause cancer and birth defects or other reproductive harm. **Wash hands after handling.**

## SPECIFICATIONS

Model Number	Free Speed (RPM)	Chuck Size	Weight (lbs)	Length (In)	Air Cons. (CFM)
6403	3600	5/16" internal hex	1-3/4	9-0	3.5

## Air Supply

Tools of this class operate on a wide range of air pressure. It is recommended that air pressure of these tools measures 90 PSI at the tool while running free. Higher pressure and unclean air will shorten the tool's life because of faster wear and may create a hazardous condition and void the warranty. Water in the air line will cause damage to the tool. Drain the air tank daily. Clean the air inlet filter screen on at least a weekly schedule. The recommended hookup procedure can be viewed in the illustration below. The air inlet, used for connecting air supply, has standard 1/4" NPT American Thread. Line pressure should be increased to compensate for unusually long air hoses (over 25 feet). Minimum hose diameter should be 3/8" I.D. and fittings should have the same inside dimensions.

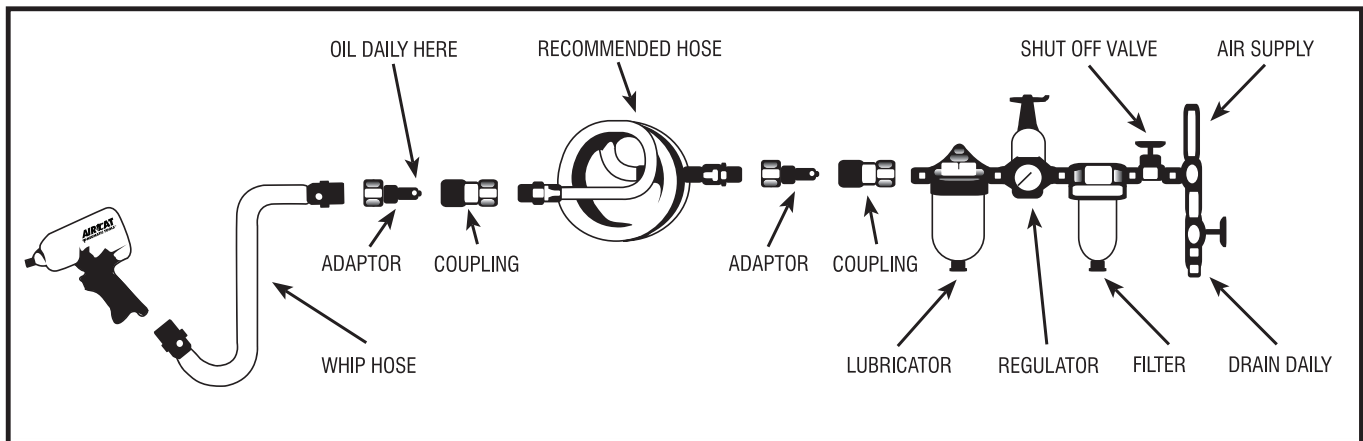

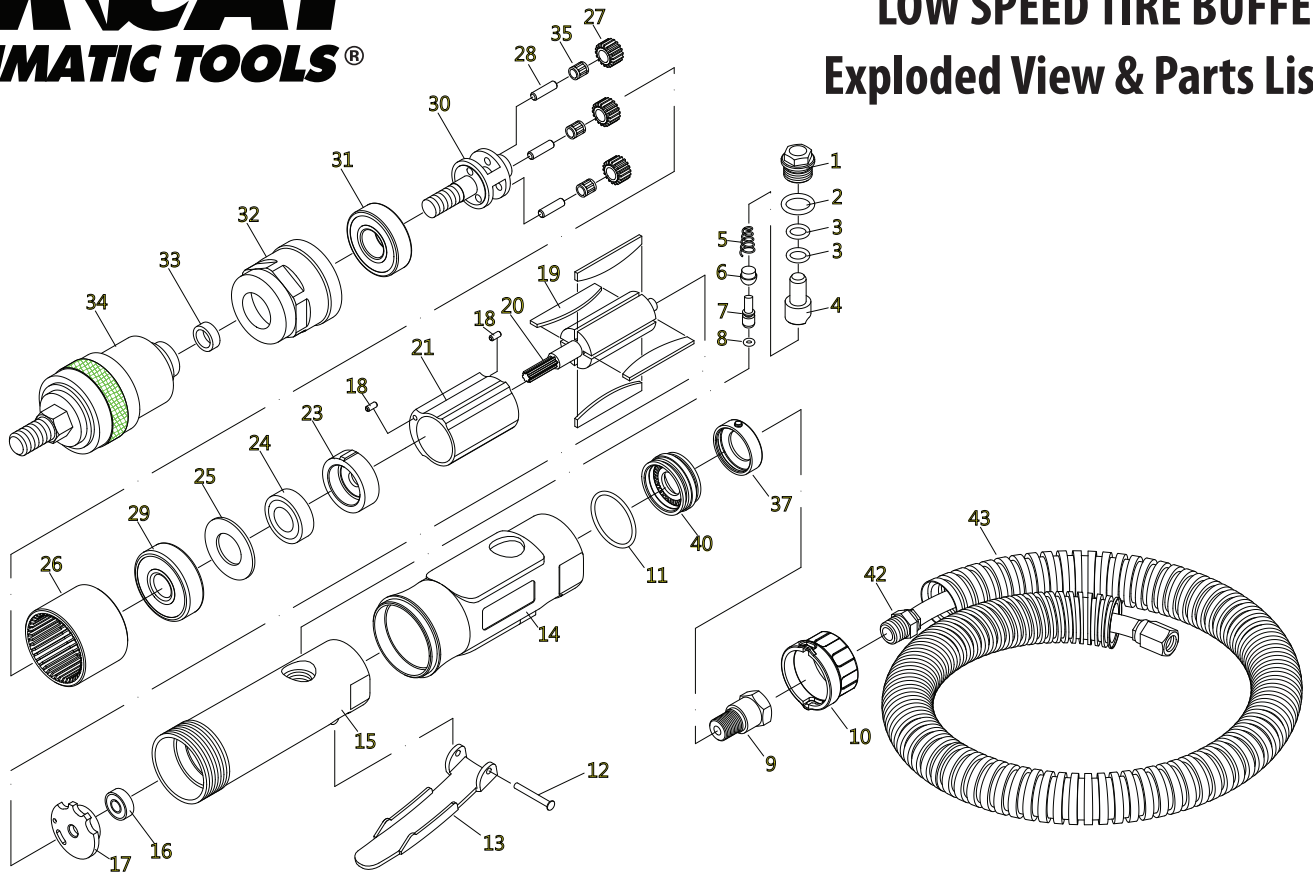

Ref #	Part Number	Description	Qty
01	970001-1	SCREW	1
02	970002-1	O-RING	1
03	970003-1	O-RING	2
04	970004-1	AIR REGULATOR	1
05	950332	SPRING	1
06	970429	VALVE STEM BUSHING	1
07	970007B	VALVE STEM	1
08	90B-04	O-RING	1
09	9ST200A09	AIR INLET (NPT)	1
09	9ST200A09-2	AIR INLET (BSP)	1
10	9ST270C10	EXHAUST ADAPTER	1
11	970011-1	O-RING	1
12	970432BK	SPRING PIN	1
13	970013BK	THROTTLE LEVER	1
14	970014-1	PROTECTING RUBBER	1
15	9ST21015	HOUSING	1
16	920312	BEARING	1
17	9ST70017	REAR PLATE	1
18	970018-1	PIN	2
19	920019	ROTOR BLADE	4
20	9ST165021	ROTOR (9T)	1
21	9ST70021	CYLINDER	1

Ref #	Part Number	Description	Qty.
23	9ST70023	FRONT PLATE	1
24	921024	BEARING	1
25	950310	WASHER	1
26	9ST28027	THREAD RING GEAR(42T)	1
27	9ST165029	IDLER GEAR (16T)	3
28	970028-1	IDLER GEAR PIN	3
29	90B-31	BEARING	1
30	926530-1	GEAR PLATE	1
31	924531A	BEARING	1
32	9ST24532	CLAMP NUT	1
33	921329-1	WASHER	1
34	927033	SHAFT RETAINER	1
35	9ST165052	NEEDLE BEARING	3
37	9ST20038	EXHAUST SLEEVE	1
40	9ST20034	MUFFLER LINK	1
42	9ST270C42A	HOSE (NPT)	1
42	9ST270C42A-2	HOSE (BSP)	1
43	9ST270C42A-3	EXHAUST TUBE	1

## Maintenance

Other factors outside the tool may cause loss of power or erratic action. Reduced compressor output, excessive drain on the air line, moisture or restriction in air pipes or the use of hose connections of improper size or poor condition may reduce air supply. Grit or gum deposits in the tool may cut power and may be corrected by cleaning the air strainer and flushing out the tool with gum solvent oil or an equal mixture of SAE#10 oil and kerosene. If outside conditions are in order and tool is out-of-warranty, disconnect tool from hose, disassemble tool, replace worn or damaged parts, clean, reassemble, and re-lubricate, or take tool to any air tool service center. For tools in warranty period, send tool direct to Warranty Center.

## Lubrication

Ensure the air line is shut-off and drained of air before removing this tool for service or changing sockets. This will prevent the tool from operating if the throttle is accidentally engaged.

An in-line filter-regulator-lubricator is recommended as it increases tool life and keeps the tool in sustained operation.

Regularly check and fill the in-line lubricator with air tool oil. Avoid using excessive amounts of oil.

Adjust the in-line lubricator by placing a sheet of paper next to the tool's exhaust ports and holding the throttle open approximately 30 seconds. The lubricator is properly set when a light stain of oil collects on the paper.

If it is necessary to store the tool for an extended period of time (overnight, weekend, etc.), generously lubricate the tool through the air inlet. Run the tool for approximately 30 seconds to ensure the oil is evenly distributed throughout the tool. Store the tool in a clean and dry environment.

Recommended lubricants: Air tool oil or any other high grade turbine oil containing moisture absorbent, rust inhibitors, metal wetting agents, and an EP (extreme pressure) additive

---

## LIMITED WARRANTY

Florida Pneumatic Manufacturing Company ("Florida Pneumatic") warrants that its AIRCAT and NITROCAT air tools will be free from defects in material and workmanship for a period of two years from the date of original purchase, except for our AIRCAT VIBROTHERM DRIVE air tools that are warranted to be free from defects in material and workmanship for 3 years from the original date of purchase (the "Warranty Period").

Because Florida Pneumatic cannot control the quality of tools sold by unauthorized sellers, this warranty applies only to tools that were purchased from Florida Pneumatic or a Florida Pneumatic authorized seller in the United States, unless otherwise prohibited by law. Florida Pneumatic reserves the right to reject warranty claims from purchasers for tools purchased from unauthorized sellers, including unauthorized internet sites. This warranty does not cover any defects due to normal wear and tear, damage due to misuse, alteration to the product, negligence, or damage due to repair by anyone other than Florida Pneumatic or its authorized service centers. This warranty applies to the tool only. This warranty does not apply to any attached accessories/consumable products, such as drill chucks, sander backing pads, air hammer retainers and chisels, "kit" accessories, or any other accessory included with the tool. This warranty is also limited to the original, end-user purchaser.

If you wish to make a warranty claim based upon a product defect, please return the tool at issue to Florida Pneumatic or a Florida Pneumatic Authorized Service Center freight prepaid and include your name, address, phone number, a copy of your receipt or other proof of purchase showing the original date of purchase, and a description of the suspected defect. A list of Florida Pneumatic Authorized Service Centers can be found at <https://www.florida-pneumatic.com/media/uploads/Service-Centers.pdf>.

Florida Pneumatic will repair or replace, in its discretion, a defective product or product part(s) covered by this warranty. You must submit your warranty claim within the applicable Warranty Period.

It is Florida Pneumatic's policy to continue to improve our products, and Florida Pneumatic reserves the right to make changes in design or construction of its products at any time without incurring any obligation with respect to products previously sold.

There are no warranties which extend beyond those stated herein. Any implied warranties that may be applicable to the tools, including implied warranties of merchantability or fitness for a particular purpose, are limited in duration to the duration of this warranty. Some States do not allow limitations on how long an implied warranty lasts, so the above limitation may not apply to you. Under no circumstances shall Florida Pneumatic be liable for any special, incidental, or consequential damages based upon breach of this warranty, breach of contract or strict liability. Some States do not allow the exclusion or limitation of incidental or consequential damages, so the above limitation or exclusion may not apply to you. This warranty gives you specific legal rights, and you may also have other rights which vary from State to State.

If you have any questions about whether a seller is authorized, call us at (800) 356-3392 or email [authorizedseller@florida-pneumatic.com](mailto:authorizedseller@florida-pneumatic.com).

FOR THE MOST UP-TO-DATE WARRANTY INFORMATION, VISIT [WWW.AIRCAT.COM/WARRANTY](http://WWW.AIRCAT.COM/WARRANTY)



851 Jupiter Park Lane | Jupiter, FL 33458  
www.florida-pneumatic.com  
Toll Free: 888-424-7228 | Fax: 561-575-9134

